

1.

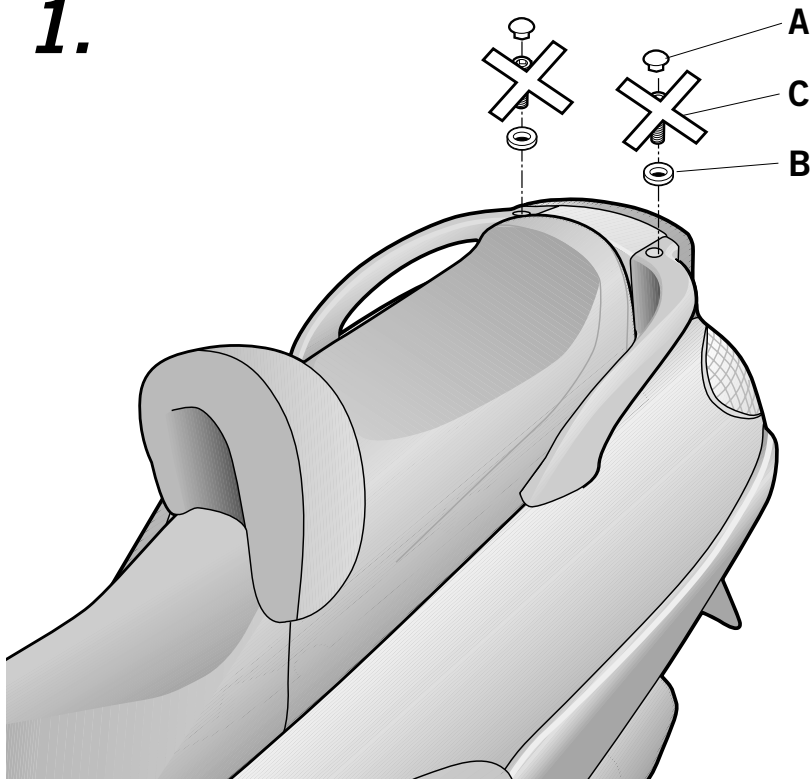

- (E)** Desmontar y desestimar los tapones (A). Desmontar y desestimar las arandelas (B) y los tornillos (C).
- (GB)** Dismantle and remove covers (A). Dismantle and remove washers (B) and screws (C).
- (F)** Enlevez les caches (A) et retirez-les. Enlevez les rondelles (B) et les vis (C) et ne n'en tenez plus compte.
- (D)** Bauen Sie die Verschlüsse aus und beseitigen Sie sie (A). Bauen Sie die Unterlegscheiben (B) und die Schrauben (C).
- (I)** Smontare ed eliminare i tappi (A). Smontare ed eliminare le guarnizioni (B) e le viti (C).

2.

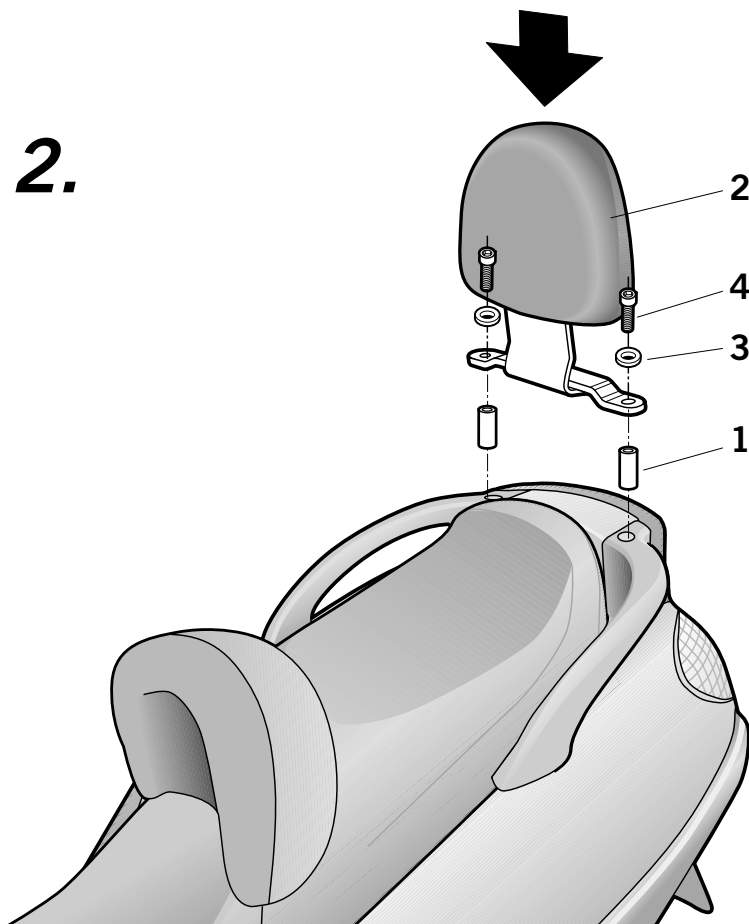

- (E)** Colocar los distanciadores (1). Montar el Kit respaldo (2), mediante las arandelas (3) y los tornillos (4).
- (GB)** Attach spacers (1). Assemble KIT support (2) using washers (3) and screws (4).
- (F)** Placez les entre-toises (1). Installez le kit d'appui (2) en utilisant les rondelles (3) et les vis (4).
- (D)** Befestigen Sie die Abstandshalter (1). Montieren Sie den Trägerbausatz (2) mit den Unterlegscheiben (3) und den Schrauben (4).
- (I)** Collocare i separatori (1). Montare il Kit schienale (2) usando le guarnizioni (3) e le viti (4).

COMPONENTES / PARTS / COMPOSANTES / EINZELBAUTEILE / COMPONENTI:

Pos.	Ref.		Cant.	
1	260611		2	Distanziador $\varnothing 13 \times 68$ - Spacer - Entre-toise - Abstandshalter - Distanziatore
2	260785		1	Kit respaldo - Kit supports - kit d'appui - Kit Rücklehne - Kit schienale
3	303017		2	Arandela esp. $\varnothing 6 \times \varnothing 18$ DIN 9021 - Washer - Rondelle - Scheibe - Rondella
4	304153		2	Tornillo M6 x 110 DIN 912 - Screw - Vis - Schraube - Vite

PIAGGIO X-9 250 '01 - AMALFI 180 '03
VOX20R
KIT RESPALDO



SHAD

REF. 500479
Edición 2ª